

# Project Submittal – Concrete - PT/Slab



## Submittal Packet - Concrete - PT/Slab

1. Plan Set Details "Typical" Conditions for Flat Concrete Substrate with links to UL/Third party Listed Assemblies and Safti-Seal Detailed FRG (Fire Rated Gasket), SSG (Smoke-n-Sound Gasket), and BSG (Butt Strip Gasket) Assemblies
2. Product Profiles and Submittal Sheets commonly used for Flat Concrete Substrate
3. Documentation:
  - Typical Detailed Assemblies
  - STC Reference Sheet
  - LEED Data Sheet

**\*\*\*Click on Blue Highlighted to follow Direct Links\*\*\***

Additional Assemblies, Solutions, & Information available at [www.saftiseal.com](http://www.saftiseal.com)

[Fire Rated Gasket Profile - Flyer](#)

[Smoke-n-Sound Gasket Profile – Flyer](#)

[Butt Strip Gasket Profile – Flyer](#)

[Double J Shaft Wall Solutions - Flyer](#)

[Resilient Channel Assembly Solutions - Flyer](#)

[Header Assemblies - HJC Clip](#)

Backing Assemblies - [NSB](#) & [FBP](#)

[Installation, Recommendations, Repair](#)

[Chemical Compatibility with Sealants](#)

[Material Safety Data Sheets](#)

[Buy American Act Certification](#)

## Assembly and Product Certifications and Leeds

### UL, ASTM & Code Standards

UL2079 (5<sup>th</sup> Edition) & CAN/ULC S115  
ASTM E814, E1966, E2837  
A1003, A653, A924, C645, C754, C955  
Sound Tested according to ASTM E90-09  
2015 & 2018 IBC

### Leed Points

MR 2.1 & 2.2 - Construction Waste: up to 2pts  
MR 4.1 & 4.2 - Recycled Content: up to 2 pts  
MR 5.1 & 5.2 - Regional Proximity  
EQ 4.1 - Low Emitting Materials  
EQ 9 - Enhanced Acoustical

# Project Submittal – Concrete - PT/Slab

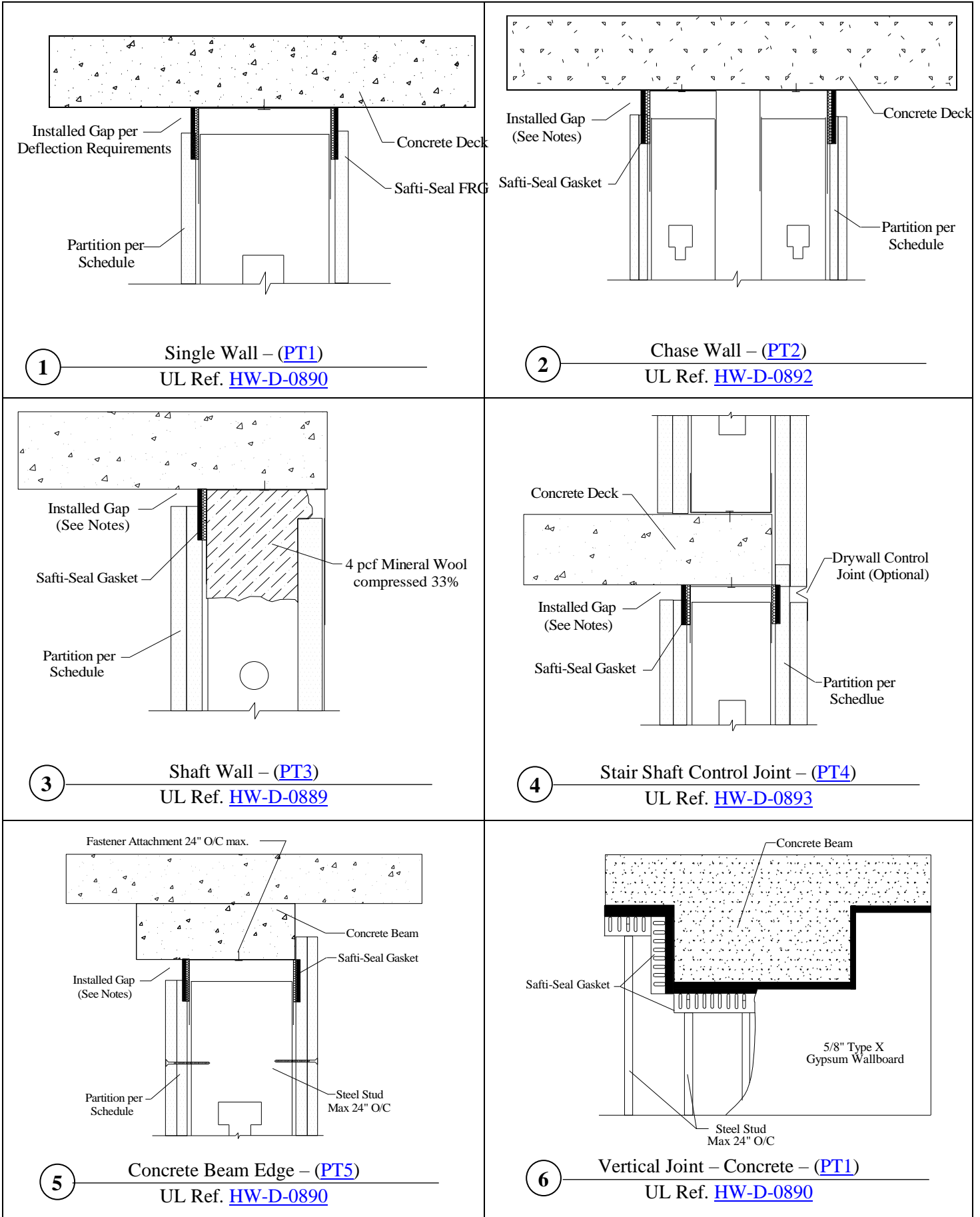

**1** Single Wall – (PT1)  
UL Ref. [HW-D-0890](#)

**2** Chase Wall – (PT2)  
UL Ref. [HW-D-0892](#)

**3** Shaft Wall – (PT3)  
UL Ref. [HW-D-0889](#)

**4** Stair Shaft Control Joint – (PT4)  
UL Ref. [HW-D-0893](#)

**5** Concrete Beam Edge – (PT5)  
UL Ref. [HW-D-0890](#)

**6** Vertical Joint – Concrete – (PT1)  
UL Ref. [HW-D-0890](#)

# Project Submittal – Concrete - PT/Slab

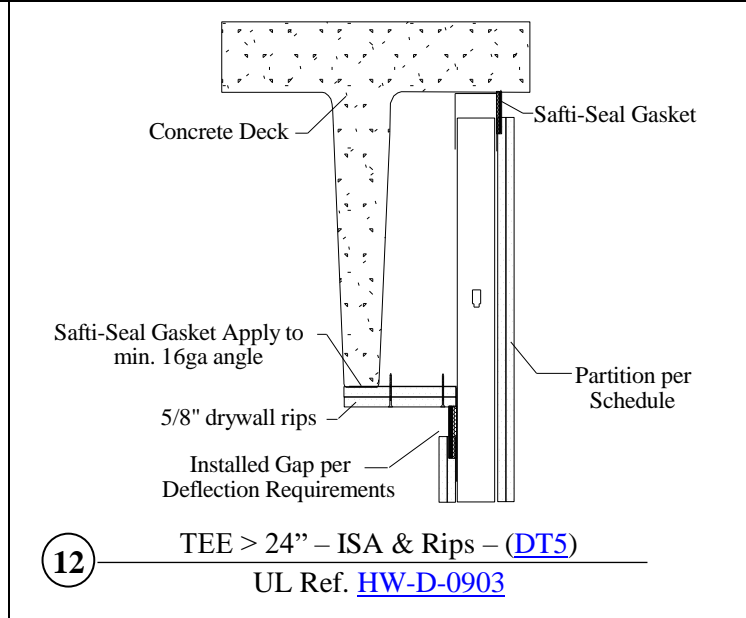
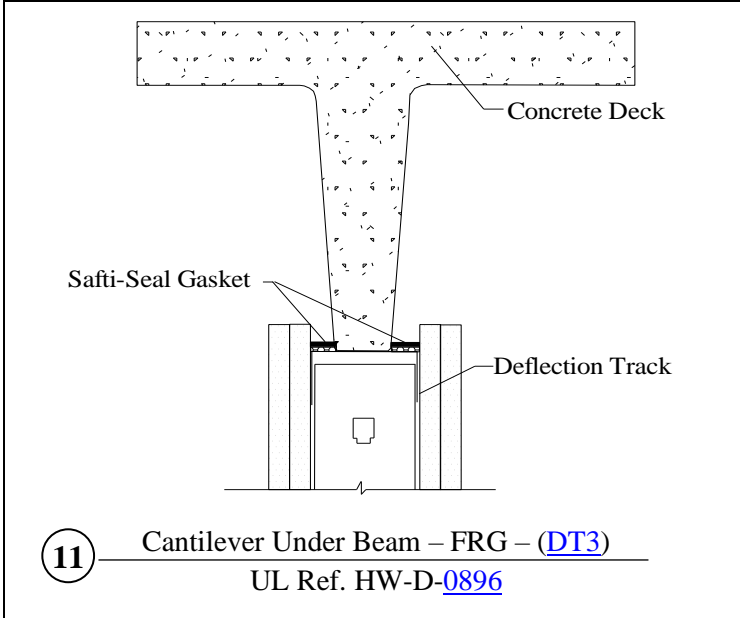
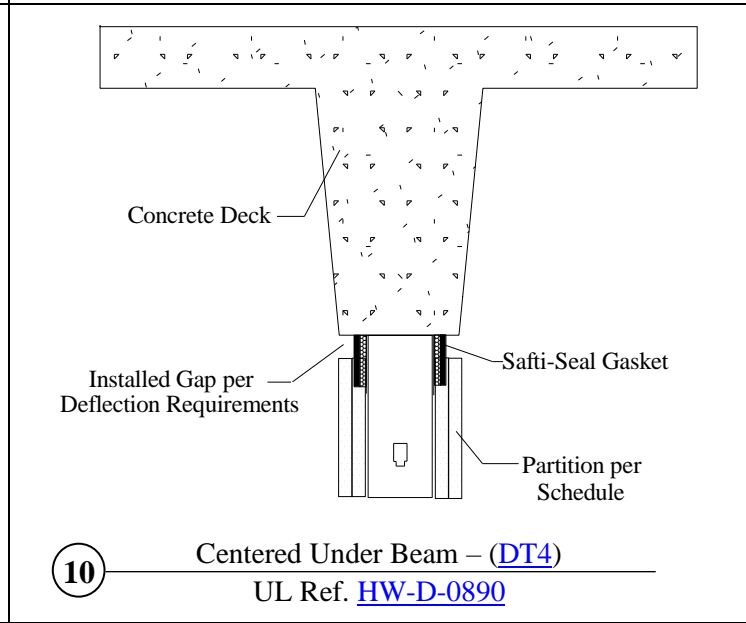
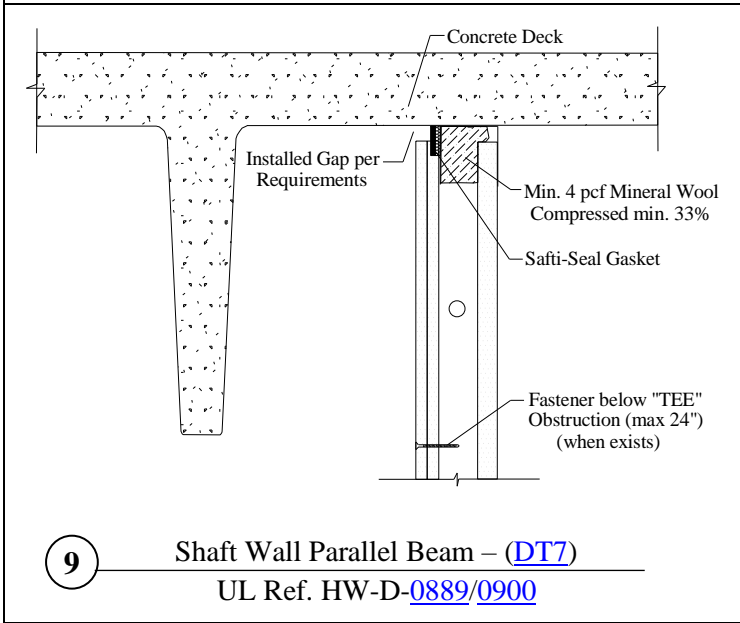
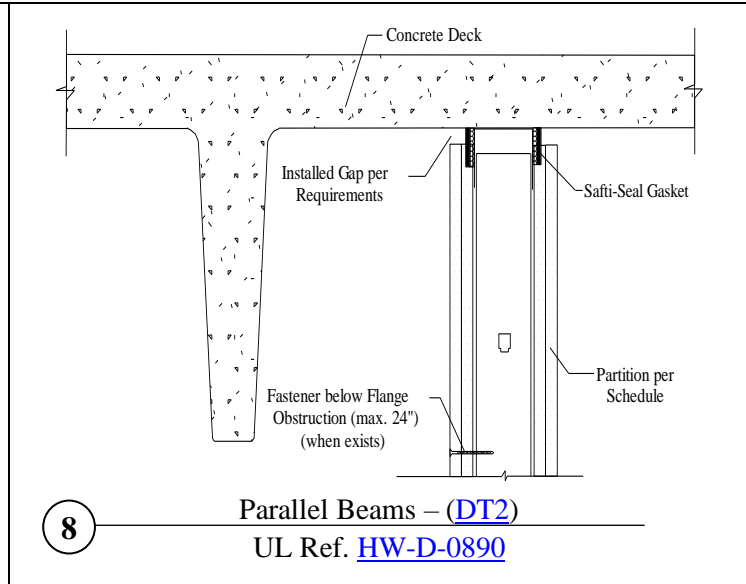
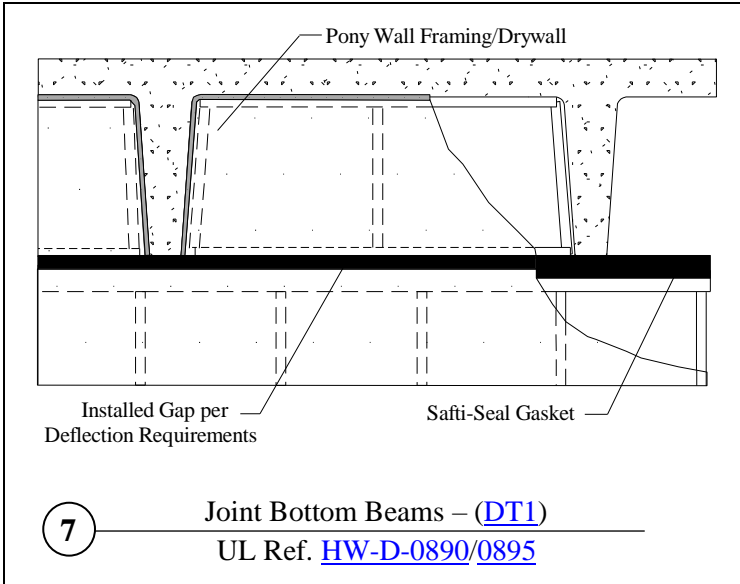

# Project Submittal – Concrete - PT/Slab

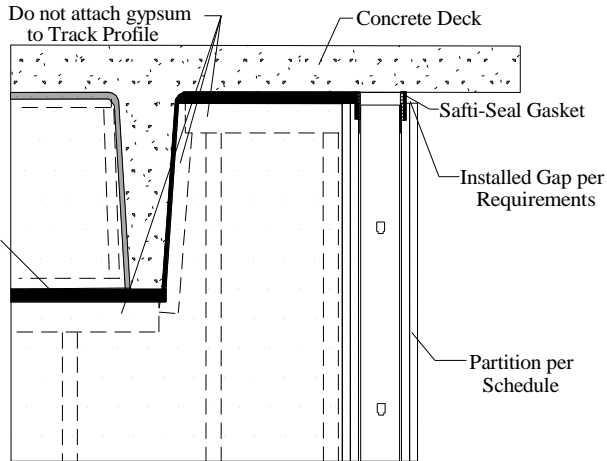

**13** Intersecting Wall Between – (DT6)  
UL Ref. [HW-D-0890/0895](#)

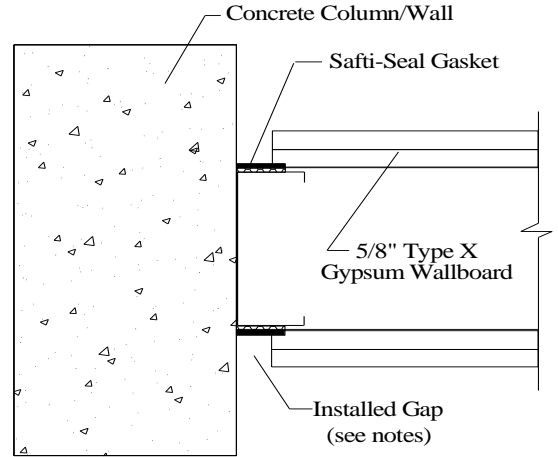

**14** Vertical – Concrete – (PT11)  
UL Ref. [WW-S-0089](#)

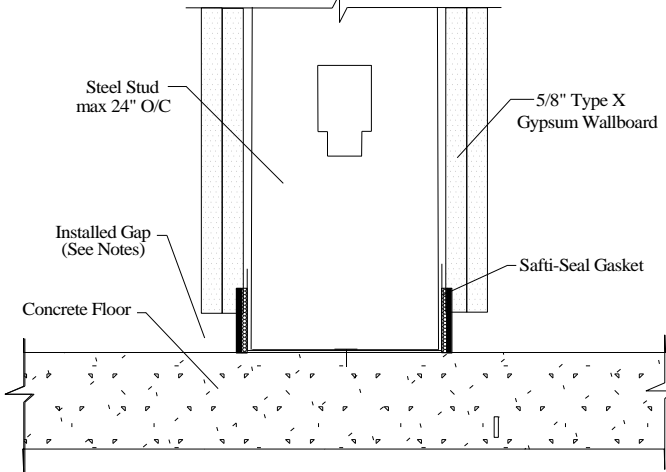

**15** Bottom of Wall – (PT6)  
UL Ref. [BW-S-0055](#)

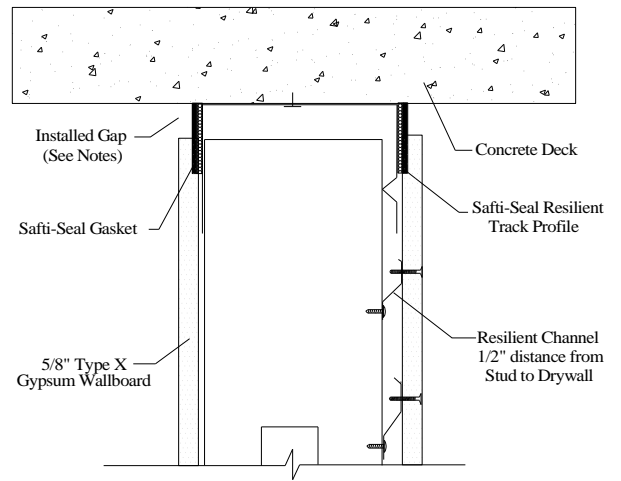

**16** Sound Wall – Resilient Channel – (PT9)  
UL Ref. [HW-D-0890](#)

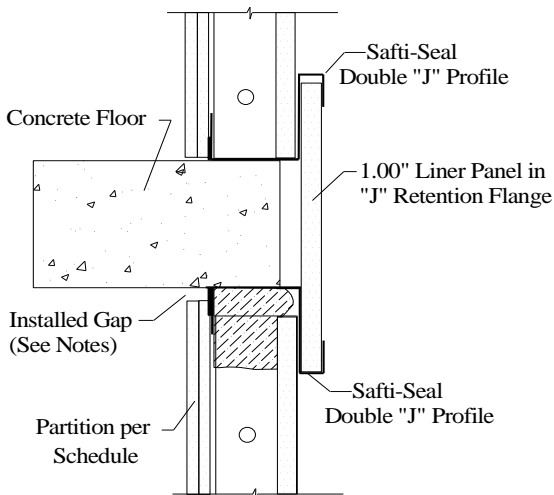

**17** Shaft Wall Double J – (PT10)  
UL Ref. [HW-D-0889](#)

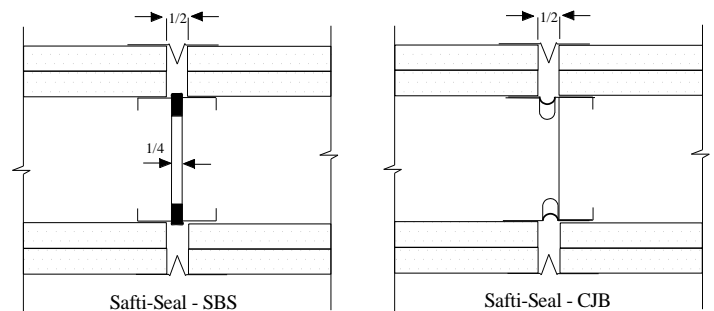

**18** Rated Control Joints BSG & CJB Options  
UL Ref. [WW-D-0257](#) & WFCi [#12033](#)

# Project Submittal – Concrete - PT/Slab

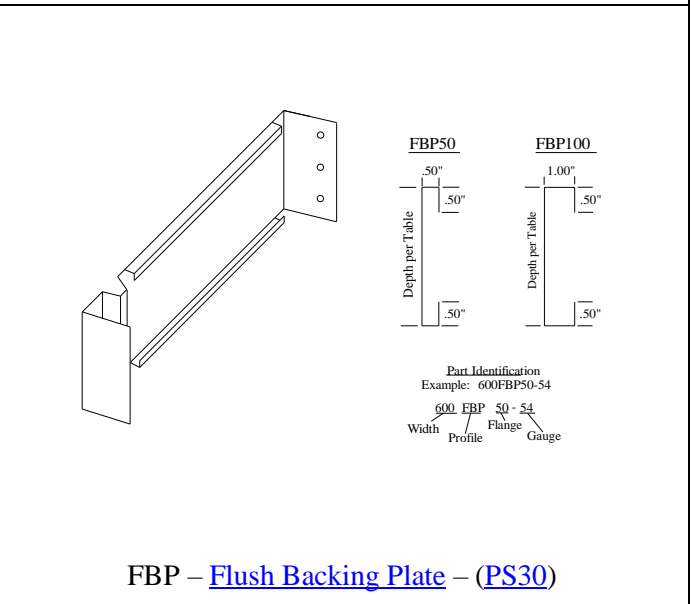
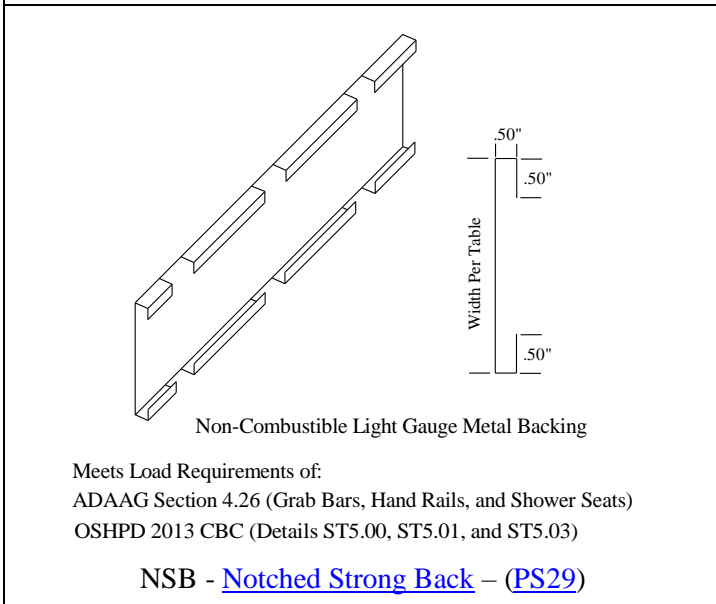
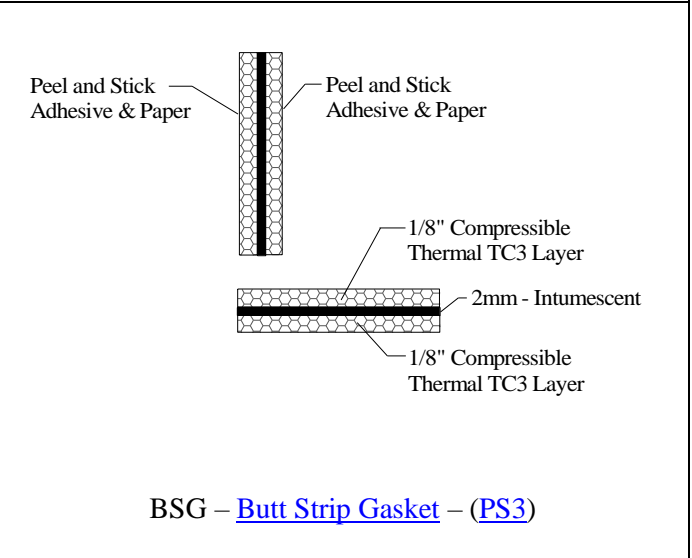
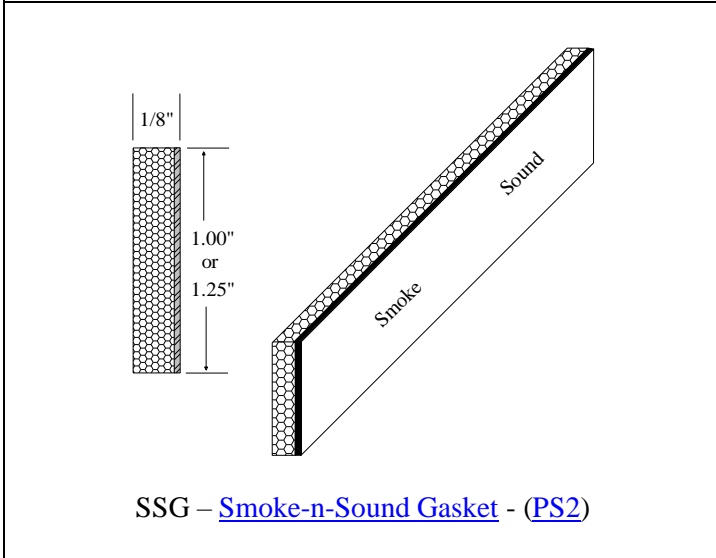
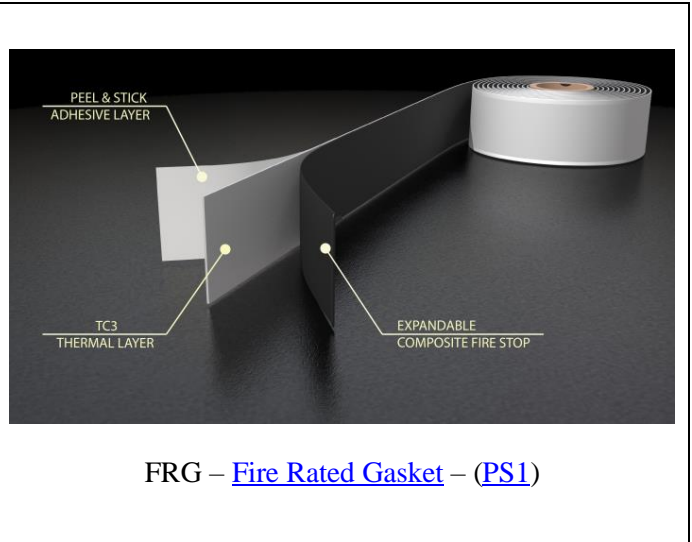
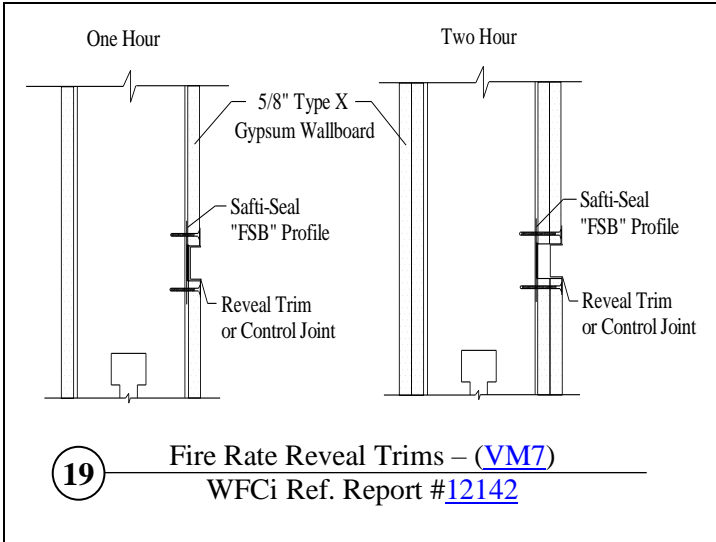



Sound Tested in Accordance  
with ASTM E90-09

### Safti-Seal Gasket Benefits

- Seat/Seal to Substrate "gasket" Protection
  - No Adhesive, Cohesive, or Substrate Failure
  - Level III Dynamic Cycle (seismic) Rated
  - Seal Flanking Paths Around Assembly
  - Dampened Sound & Vibration Transfer
  - Exposed Head of Wall and Deflection Gaps
  - Lifetime Seal - No Joint Material Fatigue
- Reports (ASTM E90-09) Click Report Number

### Safti-Seal Tested Wall Assemblies

- 1/2" to 3/4" Exposed Deflection Gaps
- 5/8" Type X Gypsum Sheathing
- 3 1/2" Fiberglass Insulation Cavity Fill

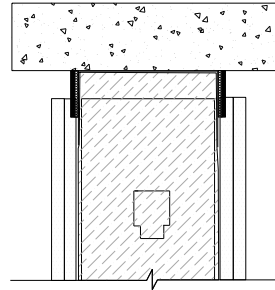

#### **STC - 51**

Single Wall Unbalanced - ([TL 17-289](#))

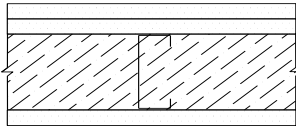

#### **STC - 55**

Single Wall Balanced - ([TL 17-288](#))

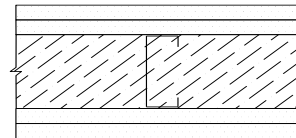

#### **STC - 63**

Chase Wall Unbalanced - ([TL 17-293](#))

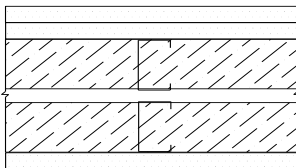

#### **STC - 64**

Chase Wall Unbalanced - ([TL 17-292](#))

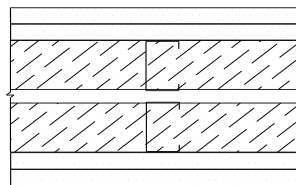

#### **STC - 64**

Flute Guard Perpendicular - ([TL 19-113](#))

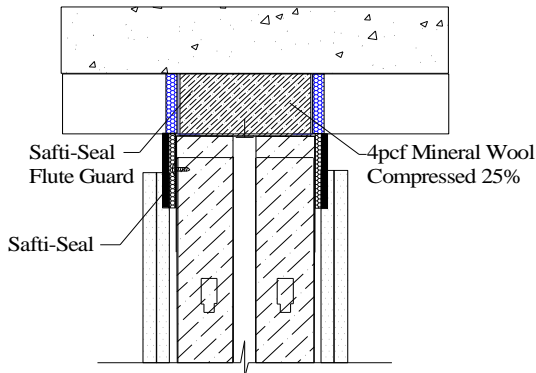

#### **STC - 54**

Resilient Channel Assembly - ([TL 19-184](#))

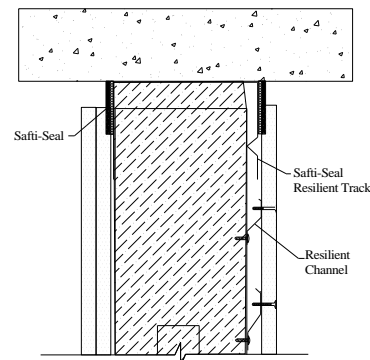



Sound Tested in Accordance  
with ASTM E90-09

## **LEED (Leadership in Energy and Environmental Design)**

The following information is provided to assist Architects and Persons responsible for obtaining a U.S. Green Building Council (USGBC) Certification.

Safti-Seal composite steel/FRG strip profiles are manufactured in Auburn, WA and consist of a ratio of steel to Safti-Strip (by weight) of approximately 90% and 10% respectively. Our product profiles qualify for the following credit requirements:

### **Steel:**

**Credit MR 2.1 & 2.2** - Construction Waste Management: up to 2 points

**Credit MR 4.1/4.2** – Recycled Content Requirements

Steel used in the manufacture of our steel profiles contains approximately 32.3% recycled steel consisting of 25.5% Post-Consumer and 6.8% Pre-Consumer.

**Credit MR 5.1/5.2** – Regional Materials Requirements (Applies for some projects)

Steel used in the manufacture of our steel profiles is purchased from sources within 500 miles of our manufacturing facility (Auburn, WA). Steel may contain local materials and recycled content, not all of the steel content generally comes from local sources.

### **Safti-Strip:**

**Credit EQ 4.1** – Low Emitting Materials: Adhesives & Sealants

Cured Safti-Strip and adhesives used in the manufacture of our profiles contain less than 10 g/l volatile organic compounds (VOC) and comply with limits established by the South Coast Air Quality Management District (SCAQMD) Rule #1168, and the Bay Area Air Quality Management District Regulation 8, Rule 51.

**Credit EQ 9** – Enhanced Acoustical

### **Why is there no LEED Certification on the product label?**

According to USGBC: “USGBC certifies buildings, not the materials that are used to construct the buildings. Only USGBC can use the LEED logo. All others violate USGBC’s registered trademark rights.”